

	Cage Code:	Title:	Date:	Rev:	Model no:
	02WL0	<b>PRODUCT DATA (subject to change)</b>	12/14/2009	None	<b>HL1-118</b>
(15H04142-01)					

**This document describes the performance of a high power limiter. Limiters are not reciprocal devices. Please be sure that high power is applied at the input port only.**

ITEM NO	CHARACTERISTIC	CONDITIONS	MIN	MAX	UNITS	COMMENTS
1	POWER SPECIFICATION	IN BAND				
1.1	FREQUENCY		30	2500	MHz	
1.2	PEAK POWER			50	WATTS	
1.3	PULSE WIDTH			CW	μs	
1.4	DUTY			CW	%	
1.5	AVERAGE POWER			50	WATTS	
1.6	CW POWER			50	WATTS	
2	POWER SPECIFICATIONS	GUARD BAND				
2.1	FREQUENCY		2500	3500	MHz	
2.2	PEAK POWER			10	WATTS	
2.3	PULSE WIDTH			1	μs	
2.4	DUTY			1	%	
2.5	AVG. POWER			1	WATTS	
3	POWER SPECIFICATIONS	OUT OF BAND				
3.1	FREQUENCY			>3500	MHz	
3.2	PEAK POWER			1	WATTS	
3.3	PULSE WIDTH			1	μs	
3.4	DUTY			1	%	
3.5	AVG. POWER			0.1	WATTS	
4	OPERATING FREQUENCY		30	2500	MHz	
5	INSERTION LOSS					
5.1	LOSS			1.2	dB	2.2 TO 2.5 GHz
5.2				.9	dB	.03 TO 2.2 GHz
6.1	FLAT LEAKAGE			15	dBm	
7	SPIKE				dBm	<b>NOT SPECIFIED</b>
7.1	SPIKE ENERGY				erg	<b>NOT SPECIFIED</b>
8	RECOVERY TIME				μs	<b>NOT SPECIFIED</b>

	Cage Code:	Title:	Date:	Rev:	Model no:
	02WLO	<b>PRODUCT DATA (subject to change)</b>	12/14/2009	None	<b>HL1-118</b>

(15H04142-01)

ITEM NO	CHARACTERISTIC	CONDITIONS	MIN	MAX	UNITS	COMMENTS
9	VSWR					
9.1	SOURCE			1.5:1		
9.2	UNIT			1.5:1		
9.3	LOAD			1.5:1		
9.4	CHARACTERISTIC IMPEDANCE					50 Ohms
9.5	AC Coupling					This Unit has internally mounted DC block
10	CONNECTORS					
10.1	RF					Type N Male on Input Type NF output
12	MECHANICAL					
12.1	WEIGHT			4.6	Oz.	
12.2	OUTLINE					DWG 4131 (below)
13	ENVIRONMENTAL					
13.1	OPERATING TEMPERATURE		-20	+70	°C	
13.2	STORAGE TEMPERATURE		-55	+85	°C	
13.3	VIBRATION LEVEL					Ground Mobile
14	SCREENING					SCREEN PER QP-121 LEVEL 3

	Cage Code:	Title:	Date:	Rev:	Model no:
	02WLO	<b>PRODUCT DATA</b> (subject to change)	12/14/2009	None	<b>HL1-118</b>

(15H04142-01)

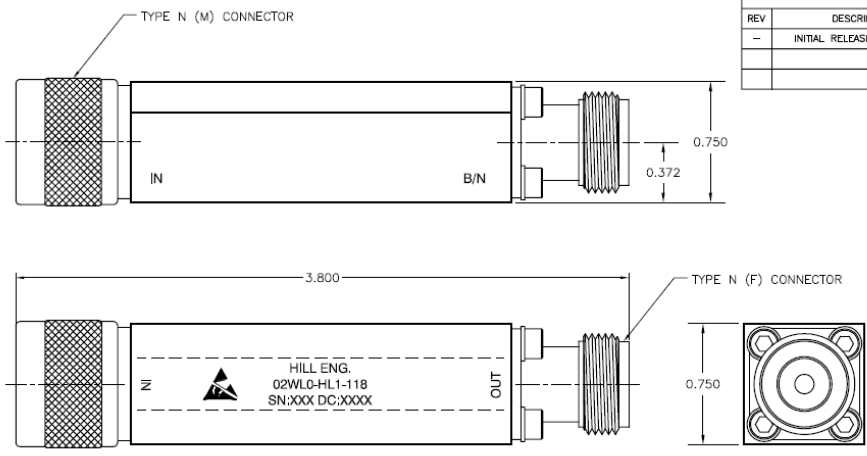

REVISIONS			
REV	DESCRIPTION	DATE	APPROVED
-	INITIAL RELEASE EDRN #2985	2/16/06	SPL

NOTES:

- FINISH:  
CHEMICAL FILM PER MIL-C-5541.
- MARKING:  
2a. MARK PER HILL ENG. MEI-147.  
2b. MARKING: .06" BLACK CHARACTERS.  
2c. LABEL: METALIZED POLYESTER SHEET  
P/N 127-0010.
- DATECODE FORMAT SHALL BE (YYWK).

<small>UNLESS OTHERWISE SPECIFIED DIMENSIONS ARE IN INCHES TOLERANCES ARE: FRACTIONS DECIMALS ANGLES SURFACE ±.004 ±.01 ±.015 ±.005 ±.010 REMOVE ALL BUMPS FROM PARTS</small>		APPROVALS		DATE	
		DRAWN BY TLB	2/14/06		
MATERIAL:		ENGINEER	2/16/06		DRAWING TITLE: OUTLINE, LIMITER
		MANUFACTURER J ALLEN	2/16/06		
HL1-118		FINISH:			SIZE B
NEXT ASSY	USED ON	CUSTOMER APPROVALS			CAGE CODE 02WLO
APPLICATIONS		DO NOT SCALE DRAWING			DRAWING NO. 4131
					REV -
				SCALE: 2/1	FILENAME: 4131-
				SHEET 1 OF 1	