

Hydrogen Filled Thyatron L4884C

The L4884C is an electron tube suitable for line type modulator switching.



Maximum Ratings	
Peak Anode Voltage (epy)	XX kV
Peak Anode Current (ib)	XX A
Average Anode Current (Ib)	XX ADC
RMS Anode Current (Ip)*	XX ARMS
Anode Current Rate of Rise (dib/dt)	XX A/μs
Anode Delay Time (tad)	XX μs
Time Jitter (tj)	XX μs
Ambient Temp	0° to 40°+ C

Ancillary Supplies	NOM	MIN.	MAX.	UNITS
Peak Control Grid Voltage (egy)				V
Control Grid Voltage Pulse Width (tp)				μs
Control Grid Voltage Rise Time (tr)				μs
Control Grid Source Drive Impedance (Zg)				Ω
Negative Control Grid Bias (Ecc)				VDC
Heater Voltage (Ef)				VAC/VDC
Heater Current at 6.3 V (If)				AAC/ADC
Reservoir Voltage (Eres)				VAC/VDC
Warm-up Time (tk)				Min.

KEY FEATURES

- * Rugged metal/ceramic construction
- * Auxiliary grid may be DC primed or pre-pulsed
- *

Hydrogen Filled Thyatron L4884C

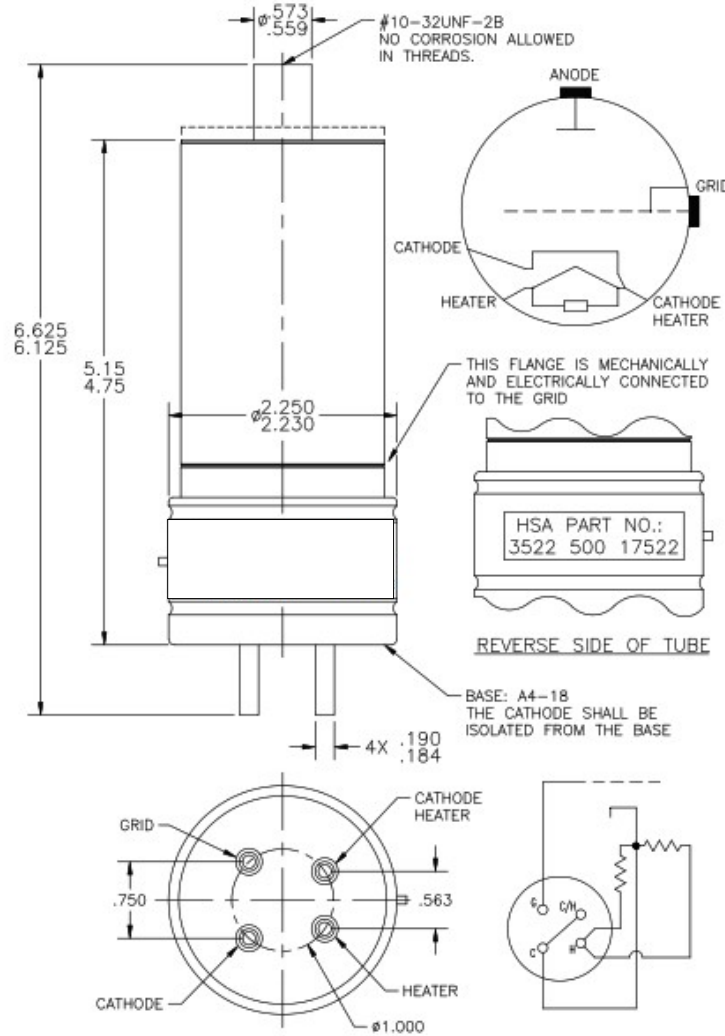

FIGURE 1

Stellant Systems is a partner for civil, military, and commercial organizations whose missions seek to ensure a safe, aware, and connected world. We are a premier manufacturer of critical spectrum and power amplification systems for defense, space, medical & scientific and industrial customers worldwide.

www.StellantSystems.com



Headquarters

3100 Lomita Blvd.
Torrance, California 90505
T: 310-517-6000
info@stellantsystems.com

1035 Westminster Dr.
Williamsport, Pennsylvania 17701
T: 570-326-3561

107 Woodmere Rd.
Folsom, California 95630
T: 916-351-4500

