

UHF IOT Tube & Trolley

80 kW CW IOT Amplifier (L4444C)

The CW 80 kW IOT is a high-efficiency tube operating in the UHF-frequency range of 470 to 810 MHz.

SPECIFICATIONS

Performance	Min	Max	Absolute Values	Units
Heater Voltage	5	7	–	V
Heater Current, Operating	20	30	–	A
Heater Current, Surge	–	60	60	A
Heater Warm-up Time	300	–	–	Sec
Beam Voltage	20	40	40	kV
Beam Current	–	3.5	4.0	A
Idle Current	0.0	0.5	–	A
Body Current	–	100	100	mA
Solenoid Current	23	27	27	A
Collector Dissipation	–	55	55	kW
Load VSWR	–	1.5:1	1.5:1	–
Bias Voltage with respect to Cathode	-50	-150	-250	V
Grid Current	–	± 150	± 150	mA
Ion Pump Current (Beam On)	–	20	20	uA
Ion Pump to Cathode Voltage	3	4	–	kV
Frequency Range (Tunable)	470	810	–	MHz
Bandwidth (-1 dB)	4.0	–	–	MHz
Gain @ 90 kW	22.0	–	–	dB
Drive Power	–	570	600	W
Output Power	–	90	90	kW
Beam Efficiency @ 90 kW	65	–	–	%

Mechanical Outline IOT

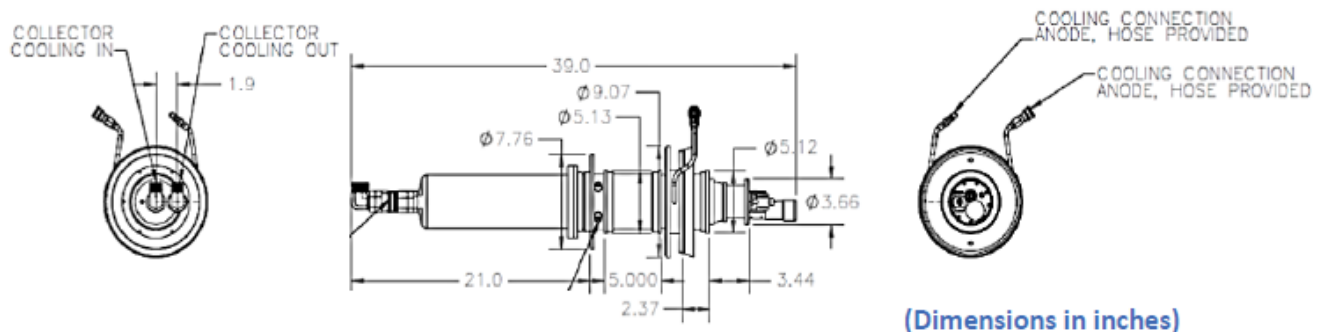

UHF IOT Tube & Trolley

80 kW CW IOT Amplifier (L4444C)

Mechanical Specification Trolley Assembly	
Electromagnet Voltage	4.5 - 7.5 V
Electromagnet Current	23 - 27 A
RF Input	Type N
RF Output	4 1/6" 50Ω coaxial line
Net Weight of Tuning Cavity	40 (approx.)
Net Weight of Magnet Assembly	250 lbs (approx.)
Collector Cooling	
Maximum Inlet Pressure	70 psi
Maximum Inlet Water Temperature	55°C
Maximum Outlet Water Temperature	75°C
Minimum Collector Flow RO or DI Water	12.5 gpm
Collector Pressure Drop	40 psi
Anode/Body/Output Cavity Cooling	
Maximum Inlet Temperature Water	55°C
Minimum Flow RO or DI Water	0.6 gpm
Pressure Drop	40 psi
Cavity Air Cooling	
Air Flow to Input and Output Cavities	125 cfm
Air Pressure at Intake	25 inches
Maximum Air Temp @ Intake	30°C

Front View of Trolley Assembly

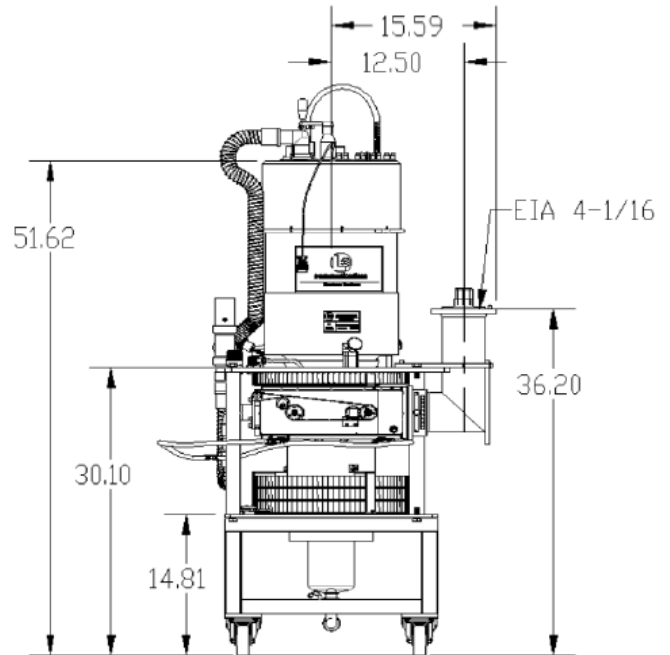

(Dimensions in inches)

Tube Protection:

A photo-resistor type arc detector is fitted to each of the primary and secondary output cavities. The beam voltage must be removed within 100 ms of an arc being detected.

Focus Coil Connector Connections:

Amphenol Connector P/N MS3102A-22-4P Mounted to Magnet Cart
Amphenol P/N MS3106F-22-4S Socket Supplied

Depicted is the Female Connector on the transmitter side

Pin	Element
A	Lid Switch
C	Lid Switch
D	Focus coil negative

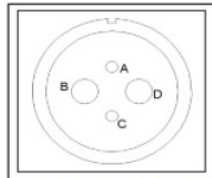

Note: Pins A and C are connected within the circuit assembly for use as an interlock circuit.

Lid Switch Interlock Connections

Pin	Connection
A	Lid Switch
B	Not Connected
C	Lid Switch

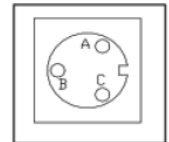

Arc Detector Connections

Test Lamp

Photo Resistor

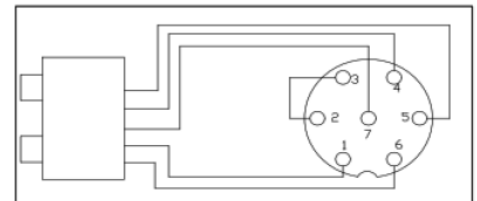

Detailed outline drawings are available on request. Specifications and features are subject to change without notice.

Headquarters

3100 Lomita Blvd
Torrance, CA 90505
T: 310-517-6000

Williamsport, PA

1035 Westminster Dr.
Williamsport, PA 17701
T: 570-326-3561



StellantSystems.com



Sales-PST@stellantsystems.com

info@stellantsystems.com