

Thyratron

L4040LD

High-voltage Switch Suitable for Medical Accelerator and Radar Applications

The L4040LD is a tetrode deuterium thyratron capable of switching peak power levels to 16.5 MW at average powers to 25 kW. The Thyratron is designed for line-type modulator applications. A large volume deuterium reservoir is incorporated to maintain stable gas pressure.

SPECIFICATIONS

Maximum Ratings	Max	Units
Peak Anode Voltage, forward ¹ (epy)	33	kV
Peak Anode Current, forward (ib)	1,000	A
Average Anode Current (lb)	1.25	ADC
Average Anode Current, Intermittent (lb)	2.2	ADC
Anode Current Rate of Rise (dib/dt)	5,000	A/μs
Anode Delay Time (tad)	0.25	μs
Time Jitter ² (tj)	0.005	μs
Ambient Temp	-50°C to +90°C	



Typical Operation	Nom	Min	Max	Units
G2 Peak Trigger Voltage ³ (Egy ₂)	-	300	1,000	V
G2 Trigger Voltage Pulse Duration (tp)	2	1	-	μs
G2 Trigger Voltage Rise Time (tr)	-	-	0.35	μs
G2 Trigger Source Impedance (Zg ₂)	-	50	500	Ω
G2 Negative Control Grid Bias (Ecc ₂)	-100	0	-150	VDC
G1 Open Circuit DC Voltage (Egy ₁)	-	75	150	VDC
G1 Short Circuit DC Current (Igy ₁)	-	50	100	mADC
Heater Voltage (Ef)	6.3	6.0	6.6	V
Heater Current at 6.3 V (If)	24	-	-	A
Warm-up time (tk)	-	5	-	Min.

Specification Notes

1. During the first 25 microseconds after conduction, peak inverse anode voltage should be limited to 10 kV in order to obtain maximum tube life.
2. Time jitter (Tj) is measured at the 50% point on the leading edge of the anode current pulse.
3. The limits of anode delay time and anode time jitter are based on the minimum trigger. Using the highest permissible trigger voltage and lower trigger source impedance significantly reduces these values below the limits specified.

Thyratron

L4040LD

Outline Drawing (inches)

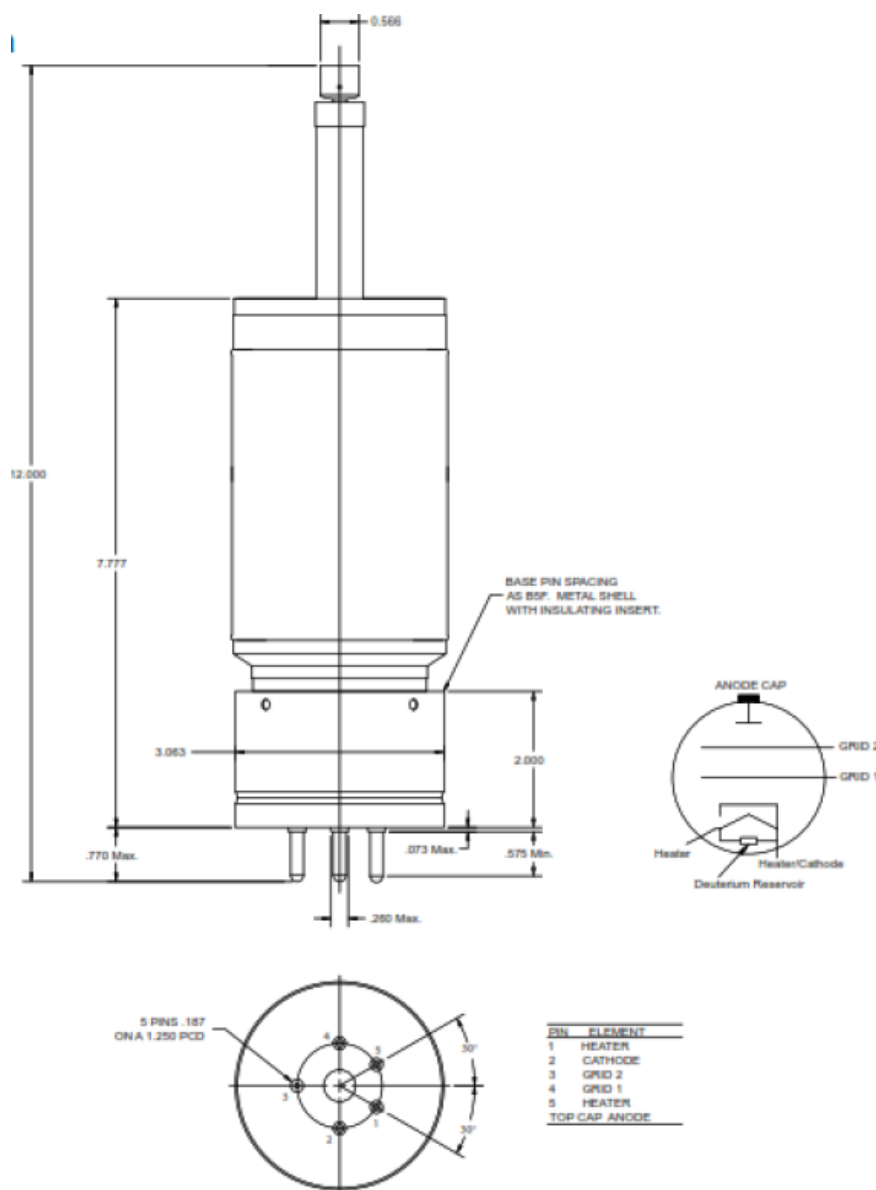

Detailed outline drawings are available on request. Specifications and features are subject to change without notice.



Headquarters

3100 Lomita Blvd
Torrance, CA 90505
T: 310-517-6000

Williamsport, PA

1035 Westminster Dr.
Williamsport, PA 17701
T: 570-326-3561



StellantSystems.com   
Sales-PST@stellantsystems.com
info@stellantsystems.com