

Hydrogen Filled Thyatron

L4884

The L4884 is an electron tube suitable for line type modulator switching.

KEY FEATURES

- Rugged metal / ceramic construction
- Auxiliary grid may be DC primed or pre-pulsed

SPECIFICATIONS

Maximum Ratings	
Peak Anode Voltage (epy)	XX kV
Peak Anode Current (ib)	XX A
Average Anode Current (Ib)	XX ADC
RMS Anode Current (Ip)*	XX ARMS
Anode Current Rate of Rise (dib/dt)	XX A/μs
Anode Delay Time (tad)	XX μs
Time Jitter (tj)	XX μs
Ambient Temp	0° to 40+°C

Ancillary Supplies	Nom	Min	Max	Units
Peak Control Grid Voltage (egy)				V
Control Grid Voltage Pulse Width (tp)				μs
Control Grid Voltage Rise Time (tr)				μs
Control Grid Source Drive Impedance (Zg)				Ω
Negative Control Grid Bias (Ecc)				VDC
Heater Voltage (Ef)				VAC/VDC
Heater Current at 6.3 V (If)				AAC/ADC
Reservoir Voltage (Eres)				VAC/VDC
Warm-up Time (tk)				Min.



Hydrogen Filled Thyatron

L4884

Outline Drawing (inches)

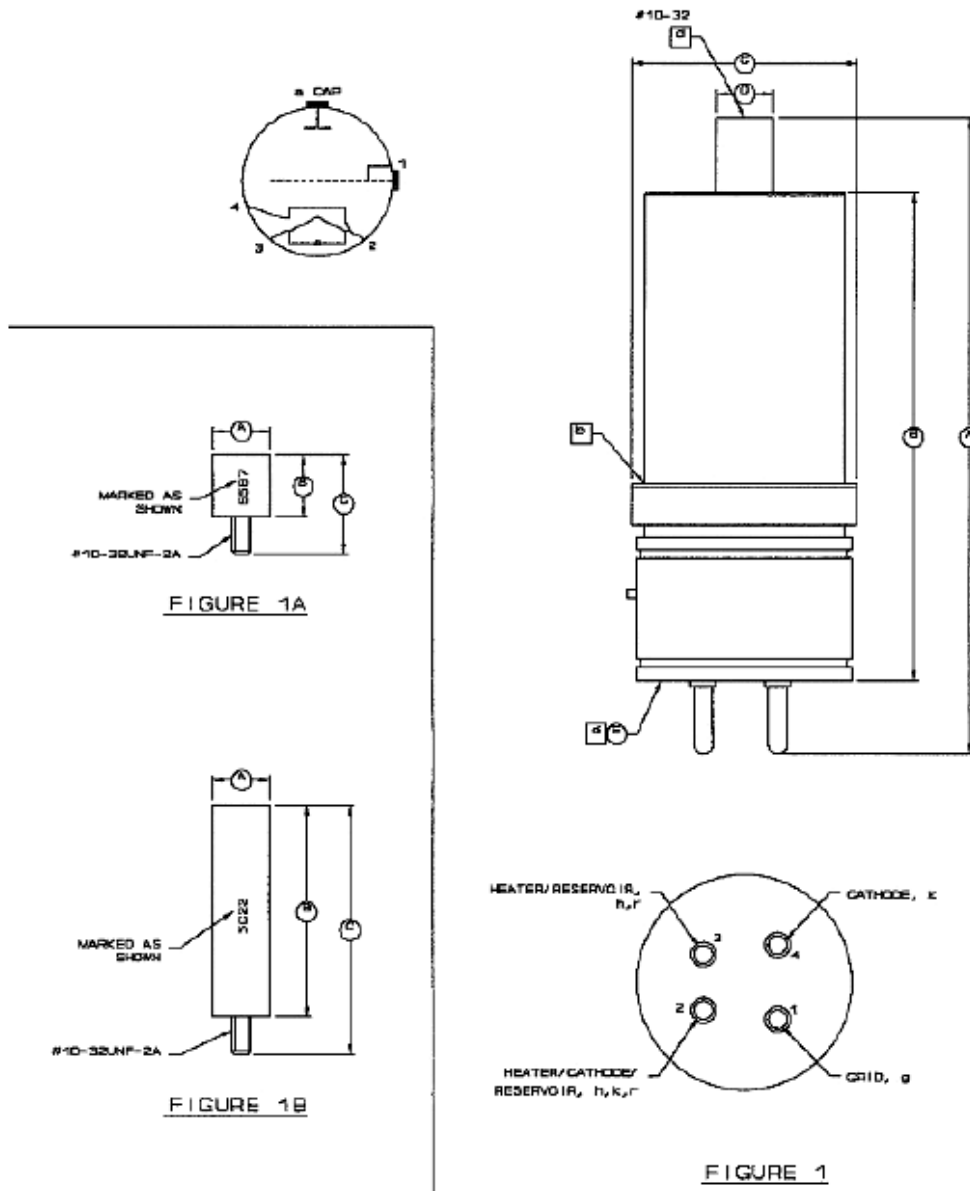

Detailed outline drawings are available on request. Specifications and features are subject to change without notice.

Headquarters

3100 Lomita Blvd
Torrance, CA 90505
T: 310-517-6000

Williamsport, PA

1035 Westminster Dr.
Williamsport, PA 17701
T: 570-326-3561



StellantSystems.com



Sales-PST@stellantsystems.com

info@stellantsystems.com